

PO03AC-100 - AC-500

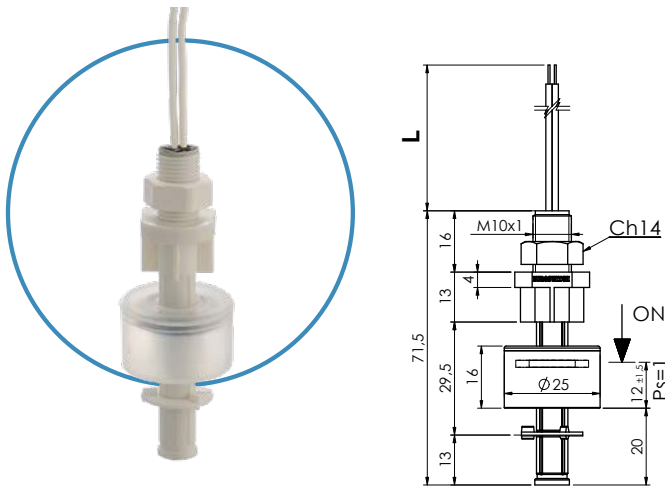

PO03AC-200 - AC-600

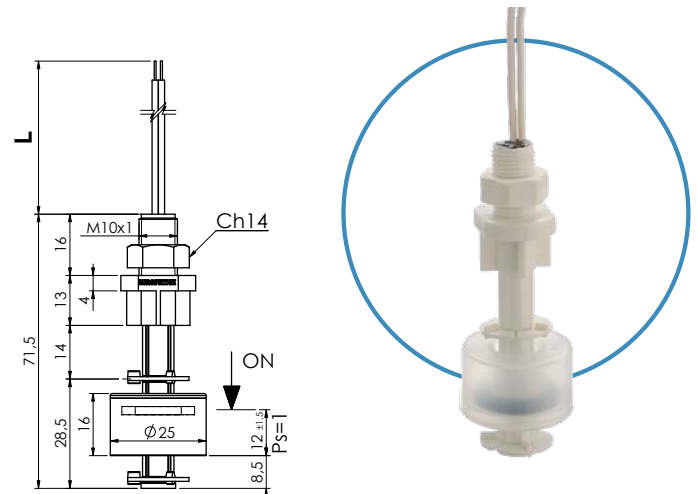

		Codice Part number			
Connessione elettrica Electrical connection					
L = 500 mm fili/wires	PO03AC - 100	PO03AC - 200	PO03AC - 500	PO03AC - 600	
L = 1 mt cavetto/cable	PO03AC - 110	PO03AC - 210	PO03AC - 510	PO03AC - 610	
L = 2 mt cavetto/cable	PO03AC - 120	PO03AC - 220	PO03AC - 520	PO03AC - 620	
Per passare da N.C. a N.A. è sufficiente capovolgere il galleggiante The contact can be converted from N.C. to N.O. by rotating the float upside down			Contatto SPDT SPDT Contact		

Nel caso di connessioni non isolate devono essere prese le adeguate precauzioni per garantire la distanza minima di sicurezza tra i diversi morsetti.
Per versioni personalizzate (tipo di cablaggio, temperatura > 80°C, tensione > 50V, ecc.) contattare Euroswitch.

When using non-insulated connections, the necessary precautions must be taken to ensure the minimum safety distance between the terminals.
For Customized version (type of cable, temperature > 80°C, voltage > 50V, etc.) please contact Euroswitch.

Impiego Use	Acqua - Acidi (Fluidi alimentari a richiesta) Water - Acids (Alimentary liquids on request)
Fissaggio Fixing	M10 x 1
Stelo Stem	Polipropilene Polypropylene
Galleggiante Float	Polipropilene Polypropylene
Dado Nut	Nylon
Tipo contatto Type of contact	Reed N.A./N.C. (SPDT) Reed N.O./N.C. (SPDT)

Max potenza commut. Max switch. capacity	40 W - (3 W SPDT)
Max corrente commut. Max switch. current	1 A - (0,25 A SPDT)
Max tensione commut. Max switch. voltage	50 V (250V a richiesta) 50 V (250V on request)
Peso specif. liquido Specific fluid weight	> 0,75
Temp. in funzionamento Working temperature	-10°C / +80°C
Peso Weight	~ gr 16