

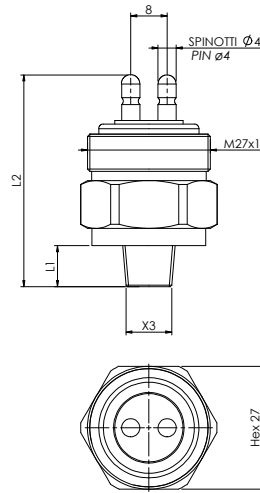

**26**

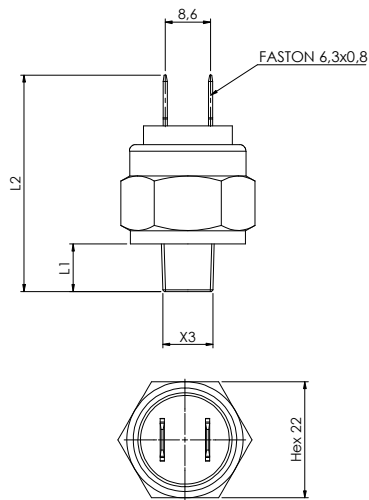

**266**

Codice Part number		Campo di intervento bar Operating range bar	
<b>Contatto elettrico norm. aperto</b> <i>Electrical contact norm. open</i>			
26	1 0 ● ■ 0	266	0 ● ■ 0
26	1 0 ● ■ 1	266	0 ● ■ 1
			1 - 4
			3 - 6

● Filetti Threads	Mod. 26		Mod. 266	
	L1mm	L2mm	L1mm	L2mm
1 - 1/8" Gas conico <i>1 - 1/8" Gas conical</i>	8	39	10	48
2 - 1/4" Gas conico <i>2 - 1/4" Gas conical</i>	10	41	12	50
3 - M10x1 conico <i>3 - M10x1 conical</i>	9	40	9	47

■ Membrane (vedi pag. 19) Diaphragms (see page 19)
1 NBR (Standard)
2 FKM
3 EPDM
6 HNBR

Corpo Case	Acciaio zincato <i>Zinc plated steel</i>
Contatti elettrici Electric contacts	Argentati <i>Silver plated</i>
Condizione elettrica Electric conditions	N.A.
Max tensione commutabile Max switched voltage	24 V
Max corrente commutabile Max switched current	2 A

Max temperatura fluido Max fluid temperature	100° C
Vita meccanica Mechanical working life	10 <sup>5</sup> operazioni (0 - 200 bar) <i>10<sup>5</sup> operations (0 - 200 bar)</i>
Max pressione di sicurezza Max overpressure limit	400 bar
Tipo di azionamento Action type	1B
Peso Weight	mod 26 ~ 35 g   mod 266 ~ 70 g